

# TRILLOGY

LABEL DIGITAL CONVERTING & FINISHING

FLEXO

SILK-SCREEN

HOT-STAMPING

LASER DIE-CUT

INSPECTION

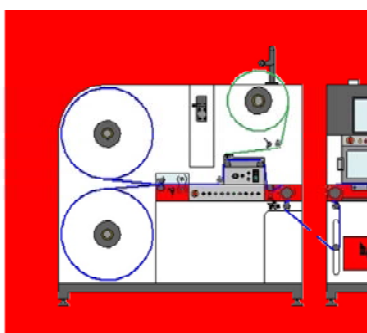
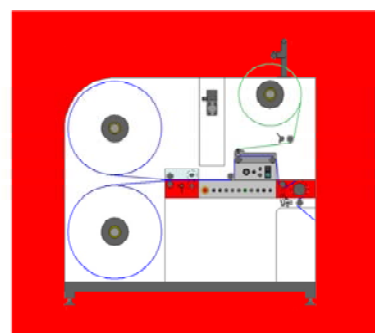
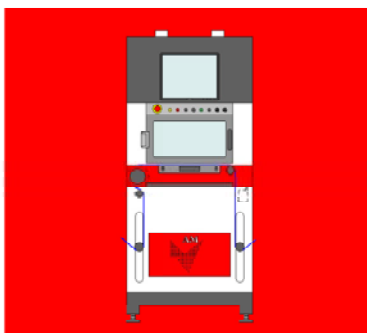
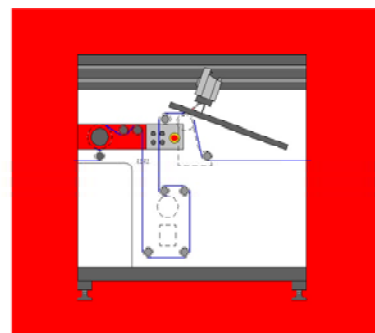
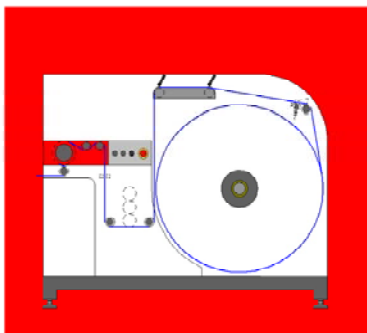
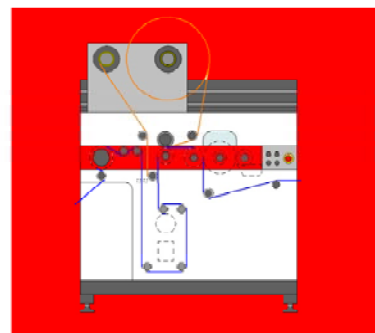

*...always one step ahead*

[WWW.AM-LASER.COM](http://WWW.AM-LASER.COM)

**TRILOGY** finishing, converting and quality control of self-adhesive labels in single step operation.

**TRILOGY** the first in the market, allows great operational flexibility, thanks to integration of traditional and innovative technologies in a fast and economical way. Let's you avoid multiple passages starting from printed rolls up to finished, certified and ready to use labels, satisfying growing finishing and converting needs, both for short and large label runs.

**Complete Modular configuration:** depending on customer's current and future needs, introduction of additional modules or additional technologies is foreseen allowing unlimited upgrade configuration while keeping low production and consumables costs.

#### Optional technologies

**Silk screen unit** : solids or 3D details

**Flexo unit** : additional spot colours, varnishing, lamination

**Cold Foil unit**

**Hot Foil unit**

**Laser die-cut unit** Totally free of geometry selection, allows infinitely variable die cutting form without die-cutting tools cost and minimal setup time and waste.

Label cut, semi-cut and microperforation as well as variable codes, can be obtained simultaneously on a variety of substrate and shapes.

Normally impossible for mechanical die cutting tools, AM proprietary laser technology guarantees precision and high speed operations on 370 and 530 mm web widths.

**Inspection unit** the artificial vision system performs label presence and quality control, laser die cutting processing and register of all stations. Vision unit is a consolidated system delivering minimal scrap, when performing security and or cost minded operations.

### TECHNICAL FEATURES

#### General

- Max roll width: 370 / 530 mm [14.57"/20.87"]
- Max speed: 30 - 60 -100 m/min [98.42'-196.85'- 328.08']
- Water chiller for chill rolls
- Uv exhaust unit
- Modular supporting structure
- Operator interface control cabinet

#### Unwinder

- Electrowelded steel frame
- Max roll diameter: 1000 mm [39.37"]
- 3" Pneumatic shaft
- Controls: product end – flag reading – junction reading
- Junction table with retaining bars
- Web guide
- Pulling unit with load cell
- Electromagnetic powder brake unit

#### Options:

- Contact-cleaning device (adhesive rollers)
- Contactless cleaning device (antistatic blowing )
- Electrostatic discharging ionizing system

#### Re-Winder

- Electrowelded steel frame
- Max diameter: 750 mm [29.53"]
- 2 rewinding differential pneumatic shaft 3" with web tension / tape control
- Max diameter matrix roll: 500 mm [19.69"]
- Slitting max 7 rolls (on 370 mm [14.57"] web); max 10 rolls (on 530 mm [20.87"] web)
- Minimum web width: 2"
- Pulling unit
- Slitting system side trimming 2 blades
- Matrix unit: adjustable pulling; heated plate; load cell controlled matrix rewinder
- Product end, break detector
- No. 3 (370 mm [14.57"] web) standard cutters unit; No. 6 (530 mm [20.87"] web)
- Electrical box

#### Options:

- Kit with 3 additional cutters

#### Movable by-pass rollers

#### Flexo unit

- Flexo-sleeve-gearless-UV unit
- Printing repeat 19" ÷ 24" / 12" ÷ 24"
- Pre-register function
- Register's type: optical automatic register
- Air cooled UV unit and chill roller

#### Screen printing unit

- Print width: 360 / 520 mm [14.17"/20.47"]
- Max print length: 406,4 mm [16"]
- Pulling unit with load cell
- Electrostatic discharging ionization system
- RKS squeegee print unit – scraper
- Pre-register function
- Register's type: optical automatic register
- Air cooled UV unit and chill roller

#### Laser die cutting unit

- Laser power: 238 Watt (single unit)
- RF discharge pumping / 0.1÷50 kHz frequency
- H<sub>2</sub>O cooling + closed loop glycol
- Estimated average lifetime: 20.000 h
- Work area: 360x300 mm [14.17"x11.81"]
- Cutting speed: >5 m/s [16.40"]
- Continuous and/or step cut mode
- Semiautomatic laser set-up with real-time laser parameters management
- Pulling unit
- Couple of electronic small balancer for speed synchronization (by step progress function)
- X/Y motorized notch reader
- Pre-register function
- Register's type: optical automatic register

#### Options:

- Double CO<sub>2</sub> + CO<sub>2</sub> laser unit
- Removable drawer to single/double passing cut
- EOLO THC 400 / 2500 smoke exhauster with carbon activated filters

#### Hot stamping unit

- Max repeat 12" ÷ 24"
- Web width 370 mm [14.57"]
- Max unwinder rewinder for foil 400 mm diameter
- Heating unit diathermic oil

#### Video inspection control

- Print quality control
- Control of personalization coherence
- Inspection unit: linear video camera, high resolution – label's report print at roll's end with production data and scraps certification.
- Back unconformity TAG for non complying tracing

#### Options:

- Delta E control

#### AM-Drive-RCM remote assistance

AM Drive RCM software option, enables direct internet connection Remote diagnostics assistance and service.

AM has the right to modify the features mentioned in own catalogues at any time and without any notice.